

# SPECIFICATION

## 1. PHYSICAL DIMENSION(UNIT: m/m):

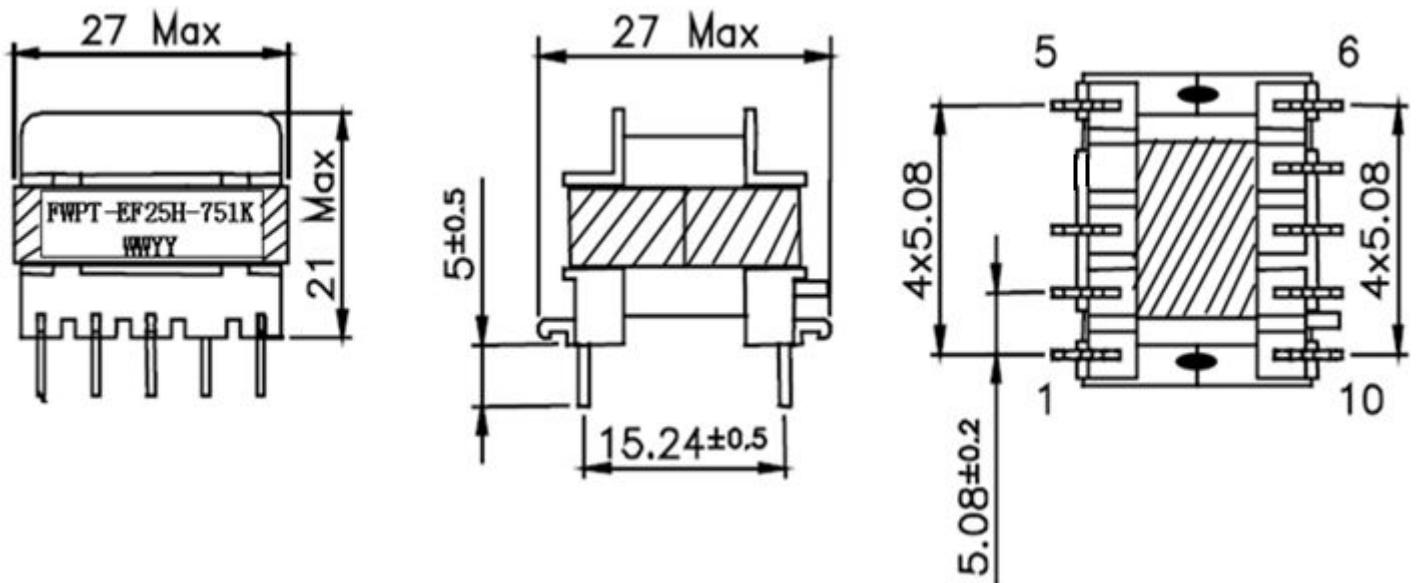

※DIMENSIONS WITHOUT TOLERANCE ARE APPROX

※DIMENSION DOES NOT INCLUDE SOLDER USED ONCOILS

Note:PIN4 cut off

**LEAD FREE**

DIM	A	B	C	D	E	F	G	H				
SPEC												
						DESCRIPTION			TRANSFORMER			
						Customer P/N						
						FERRIWO P/N			FWPT-EF25H-751K			
SPEC. NO.	PS-1001-001				PREPARED			APPROVED				

# SPECIFICATION

## 2.WINDING TABLE:

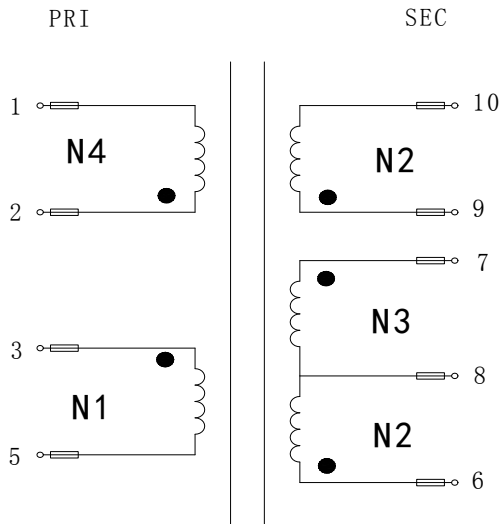

## 3.WINDING:

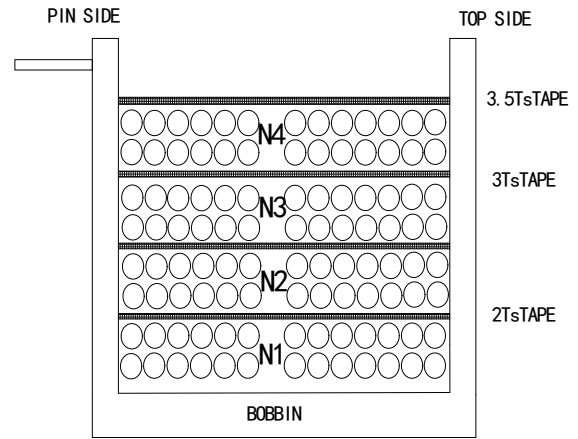

## 4.WINDING TABLE:

Winding NO.	Margin Tape	PIN	Wire & Wire Copper	Turns	Winding Type	Tape Layer	Tube
N1	0	3~5			Compact	2	F=S=7mm
N2	0	6~8 9~10			Compact Compact	2	F=S=7mm F=S=10mm
N3	0	7~8			Compact	2	F=S=10mm
N4	0	2~1			Dispersed	2.5	F=S=10mm

### NOTE:

- Pin 1 should be outside when the bobbin insert into the winding machine.
- Products should be vacuum impregnation
  - \*VARNISH RATIO: 1:1
  - \*VACUUM TIME: 15~20minutes
  - \*BAKED TEMPERATURE : 120°C±10°C, 1~1.5hours

The label as the follow picture:

**LEAD FREE**

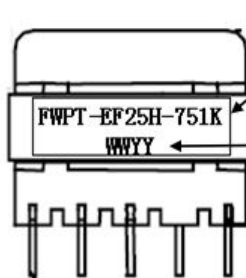

FWPT:FERRIWO POWER TRANSFORMER  
EF25H:BOBBIN ADN CORE P/N  
751K:750uH±10%

WW:WEEK  
YY:YEAR

**FERRIWO**

DESCRIPTION

TRANSFORMER

Customer P/N

FERRIWO P/N

FWPT-EF25H-751K

SPEC. NO.

PS-1001-001

PREPARED

APPROVED

# SPECIFICATION

## 5. ELECTRONICAL CHARACTERISTIC:

TEST CONDITION : TEMPERATURE AT 25°C

HUMIDITY AT 65 ±5% RH

TEST ITEM	TEST CONDITION	RESULT
INDUCTANCE CH-3250	@100.0KHz,1.0V (3~5)	750.0μH±10%
D.C.R CH-502	(3~5)	260mΩ MAX
HI-POT TEST CH-9052	@ 2mA 3SEC (AC)	P<->S 4.0 KV; N1<->N5 1.5KV; COIL<->CORE 0.5KV

**LEAD FREE**

**FERRIWO**

DESCRIPTION

TRANSFORMER

Customer P/N

FERRIWO P/N

FWPT-EF25H-751K

SPEC. NO.

PS-1001-001

PREPARED

APPROVED

# SPECIFICATION

## 6. MATERIAL LIST :

ITEM		MATERIAL	SUPPLIER OR MANUFACTURER	TEMPRATING
1	CORE	FW40 OR EQUIVALENT	HAINING FERRIWO ELECTRONICS CO., LTD.	
2	BOBBIN	PHENOLIC OR EQUIVALENT	HAINING FERRIWO ELECTRONICS CO., LTD.	150℃
3	WIRE	UEW	PACIFIC ELECTRIC WIRE&CABLE(SHENZHEN) CO. LTD UL NO E84081	130℃
4	TRIPLE WIRE	TRIPLE. INSULATION. WIRE TRW(B)	GREAT LEOFLON INDUSTRIAL CO.,LTD UL NO E211989	130℃
5	TAPE	CT280	YAHUA STICKING TAPE CO.,LTD UL NO E165111	130℃
6	TUBE	TEFLON TUBE	GREAT HOLDING INDUSTRIAL CO.,LTD UL NO E156256	200℃
8	VARNISH	R-1038	ZHEJIANG RONGTAI TECHNICAL INDUSTRY CO.,LTD	130℃
9	Flux	TF9100	LINAN GUITONG CHEMICAL TECHNICAL CO.,LTD	
10	Tin	Sn99.3Cu0.7	HAINING ZHUCHANG METAL FOIL CO;LTD	
11	EPOXY	E-500 (black)	SUZHOU EATTO ELECTRONIC MATERIAL CO.,LTD	130℃

**LEAD FREE**



DESCRIPTION

TRANSFORMER

Customer P/N

FERRIWO P/N

FWPT-EF25H-751K

SPEC. NO.

PS-1001-001

PREPARED

APPROVED